

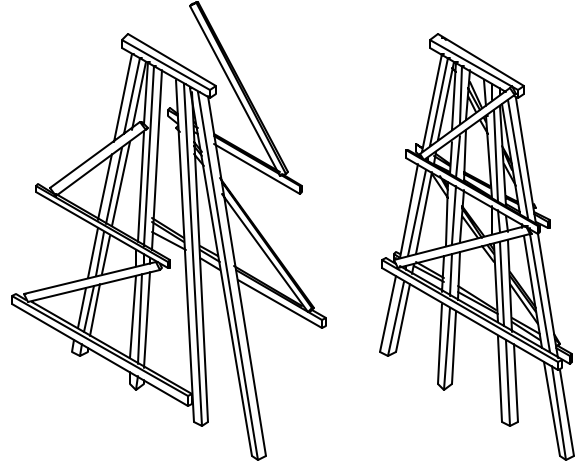

Narrow Gauge railroads are often used in industrial or short line operations. These areas often require drainage that can be provided by trestles. Black Bear Trestle Jigs can be used to build trestles of any height and in a variety of designs. If taller trestles require multiple stories, they can be modeled in any of the methods described below.

False Frame Bent

A true frame trestle bent is shown at the bottom of the page. True frame bents are hard to build and very weak because of all the butt glue joints. The **FALSE FRAME BENT** at the right is much easier to build, is very strong, and most folks (modelers or not) will be just as impressed. The difference is that the sills, which prototypically break the legs into separate pieces, are simulated by side braces. In this way you get the distinctive shape of a timber trestle bent, without the drawbacks of the true frame bent. Build the bents any height by extending the legs out the end of the jig.



Notched Frame Bent

The **NOTCHED FRAME BENT** is an excellent compromise between the ease and strength of the false frame bent and the authenticity of the true frame bent. One of the best articles on trestle building ("Tackle a Timber Trestle", John S. Corbet, *Model Railroader*, Dec '63, p 54; republished in Kalmbach's *Model Railroad Bridges and Trestles*) describes the notching of the sills and the legs to create a bent that looks prototypical from one side. These instructions describe an easy, reliable, and teachable process for notching the parts. They look great. Build the bents any height by extending the legs out the end of the jig.

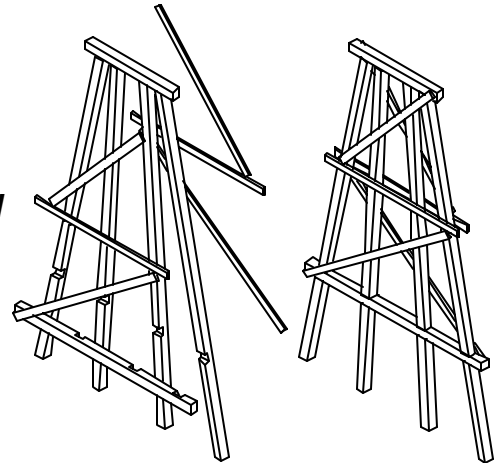

True Frame Bent

For the ultimate modeling experience, nothing beats prototype modeling. Option 3 of the instructions describes how to use the Black Bear Trestle Jig to build **TRUE FRAME BENTS**. The jig is also used to cut the parts to length. You can easily adjust the height of the sills so your bent can have several different sill spacings. Building bents taller than 40' may require the modeler to build a fixture to register the lower posts.

