

PRESS RELEASE AUGUST 3, 2002

MORE TRESTLE JIGS FROM BLACK BEAR CONSTRUCTION CO.

Black Bear Construction Co., Inc., today announces completion of its phased release of seventeen new trestle jigs for modeling frame trestle bents. The jigs are now available in four scales (N, HO, S, and O), and are based on prototype designs of three railroads: Rio Grande Southern (narrow gauge), Denver & Rio Grande Western (standard and narrow gauges), and Alamogordo & Sacramento Mountains (standard gauge).

Frame bents are unique in that they have horizontal sills that intersect the vertical legs of a trestle bent. Until now, all Black Bear jigs have been for continuous legs that extend all the way from the top cap to the ground. Frame bents were typically used in areas that had shorter trees available for building bents, such as New Mexico and parts of Colorado.

THREE TYPES OF BENTS - ONE JIG

The frame bent jig, full size drawing, materials, and instructions, allow the modeler to build accurate bents with these different levels of detail: true, notched, or false frame.

An experienced modeler with the time and inclination can use the jig to build **TRUE FRAME BENTS**. The jig is used to cut the vertical legs to length. You can easily adjust the height of the sills so the bent can have several different sill spacings. The kit includes a strip of wood that "holds the place" of the horizontal sill while the stories are being assembled in the jig. Building bents taller than 40' may require the modeler to build a fixture to register the lower posts.

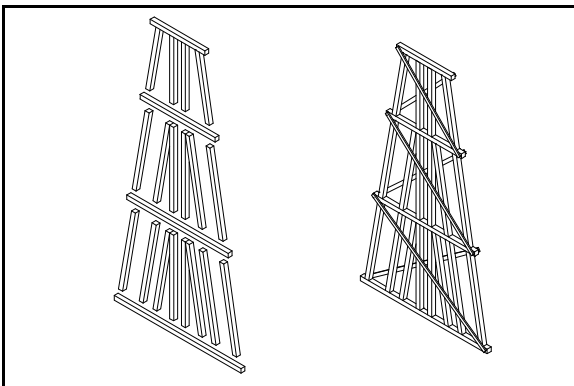

Figure 1-True (prototypical) frame trestle bent. The RGS bent is shown.

The **NOTCHED FRAME BENT** is an excellent compromise between the ease and strength of the false frame bent and the authenticity of the true frame bent. One of the best articles on trestle building ("Tackle a Timber Trestle", John S. Corbet, Model Railroader, Dec 1963, p. 54; republished in Kalmbach's Model Railroad Bridges and Trestles) describes the notching of the sills and the legs to create a bent that looks prototypical from one side. The jig instructions describe an easy and reliable

process for notching the parts. The bents can be built to any height by extending the legs out the end of the jig.

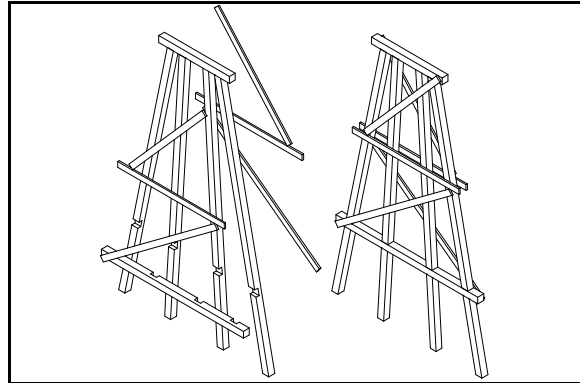

Figure 2-Notched frame bent looks prototypical on one side but is much stronger than true frame bent. D&RGW standard gauge bent is shown.

The **FALSE FRAME BENT** is the easiest way to model frame bents. Also, the bents are very strong because the vertical legs are not cut in any way. The difference is that the sills, which prototypically break the legs into separate pieces, are simulated by side braces. In this way you get the distinctive shape of the frame trestle bent, without the drawbacks of the true frame bent. The bents can be built to any height by extending the legs out the end of the jig.

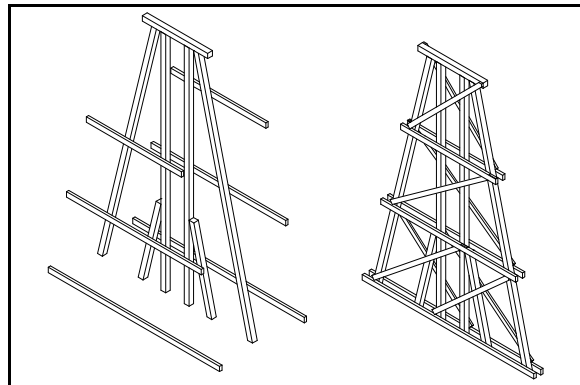

Figure 3-False frame bent is easiest to build and still looks great. The ASM bent is shown.

RIO GRANDE SOUTHERN (RGS)

There are a lot of trestles on the RGS, and all the bents are a little bit different. The curved trestles in the Gallagher Creek, CO, area are the basis for the standard Black Bear RGS frame bent. The design is based on Joe Sacks' drawings in The RGS Story Vol. IV, Sundance Books, pp. 358-360.

Black Bear Construction Co., Inc. PO Box 26911,
Austin, TX 78755-0911, (512)467-8400, FAX:
(512)458-8765, www.blackbearcc.com

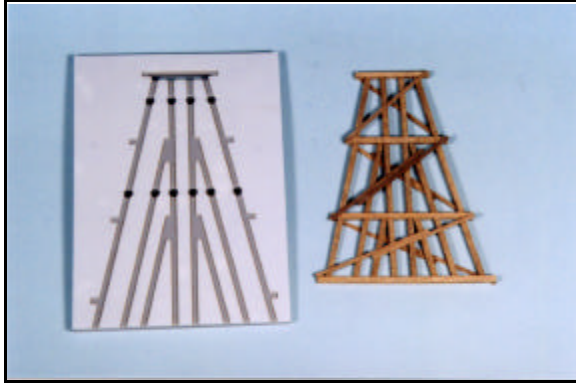

Figure 4 - RGS bents from Gallagher Creek area are available in N, HO, S, and O scales. TJ4RHO is shown.

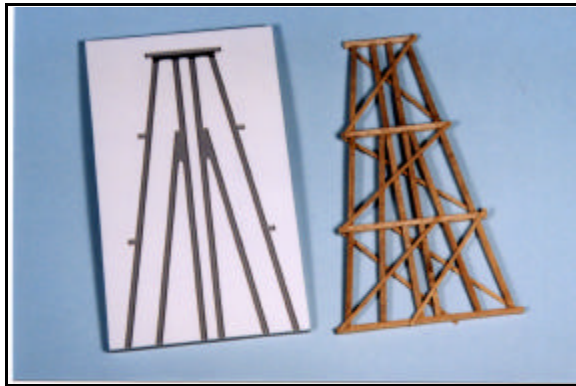

Figure 5 - One HO scale jig (TJ4HOA) is based on a David Bigge article in the Gazette.

David Bigge published the dimensions of a “typical” RGS bent in his article “Trestle Building, Rio Grande Southern Style” (Narrow Gauge and Short line Gazette, Jan/Feb, 1987, p. 22). This bent is the basis for one of the HO scale Black Bear jigs, TJ4HOA.

DENVER & RIO GRANDE WESTERN (D&RGW)

A prototype drawing provides the basis for the narrow gauge version of the D&RGW trestle bent.

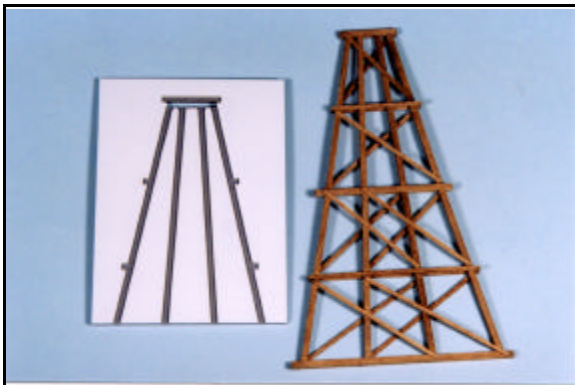

Figure 6 - D&RGW narrow gauge trestle bent jig - TJ4DNHO.

The distinctive shape (four straight legs all tilted

toward the center) is seen on a number of standard gauge railroads of the same era. For lack of a better descriptive name, this jig is referred to as the Standard Gauge D&RGW design.

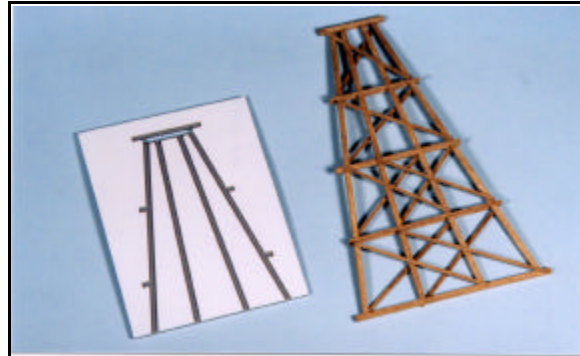

Figure 7-Standard gauge version of the D&RGW trestle bent, TJ4DSHO.

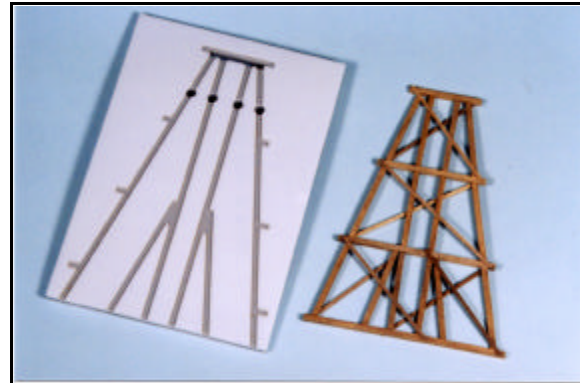

Figure 8-The standard gauge ASM bent is very similar to the RGS bent. TJ4AHO is shown.

ALAMOGORDO & SACRAMENTO MOUNTAINS (ASM)

The ASM is a standard gauge logging railroad that operated in southern New Mexico in the early 1900's. There are several large trestles near Cloudcroft, NM. The one in Mexican Canyon is still standing and is the basis for this trestle bent design.

RETAIL PRICE LIST

P/N	Prototype	Scale	Std/Ng	MSRP
TJ4RN	RGS	N	Ng	\$15.95
TJ4RHO	RGS	HO	Ng	\$22.95
TJ4RHOA	RGS	HO	Ng	\$22.95
TJ4RS	RGS	S	Ng	\$28.95
TJ4RO	RGS	O	Ng	\$37.95
TJ4DNN	D&RGW	N	Ng	\$13.95
TJ4DNHO	D&RGW	HO	Ng	\$16.95
TJ4DNS	D&RGW	S	Ng	\$22.95
TJ4DNO	D&RGW	O	Ng	\$28.95
TJ4DSN	D&RGW	N	Std	\$13.95
TJ4DSHO	D&RGW	HO	Std	\$16.95
TJ4DSS	D&RGW	S	Std	\$22.95
TJ4DSO	D&RGW	O	Std	\$28.95
TJ4AN	ASM	N	Std	\$15.95
TJ4AHO	ASM	HO	Std	\$22.95
TJ4AS	ASM	S	Std	\$28.95
TJ4AO	ASM	O	Std	\$37.95